



**Power measurement**

**Signal analysis of motor current**

**Vibro-acoustical diagnosis**

**Automatic unbalance measurement**

**Automatic test sequence**

---

## **Balancing and diagnosis system for complete automobile cooling fans**

**EEJH**

### **Application**

Performance and objective noise test in final inspection of complete automobile fans

Measurement of dynamic and static unbalance in the fan plane for optimum unbalance correction.

### **Test Method**

Signal analysis of motor current in the time and frequency range for detection of commutation errors.

Measuring of electrical power, revolution and direction of movement

VAD-method (vibro-acoustical diagnosis) for objective noise test by analysis of the structureborne noise signal in the time and frequency range.

Determination of static and dynamic unbalance with manual fan indexing and operator guidance for manual unbalance correction.

## Features

- Modular design with freely definable position of test rotors (e.g. original mounting position)
- One-channel or multi-channel objective noise test with integrated unbalance detection, optional testing of body noise
- Flexible application, simple change-over for different motor types
- PC-controlled test sequence
- Software modules for measuring of power output and VAD-methods as well as measuring of static and dynamic unbalance, large type data memory, operator guidance, diagnosis routines, statistics, process control, external interfaces.
- System adaptation to requirements of objective noise test such as insulation against structure-borne noise as well as highly repeatable sensor connection and clamping adapted to the test specimen.
- Control of brushless motors

## Layout (example)

- Machine frame with unbalance measuring and calibration system
- Protective housing with widely opening loading door
- Integrated measuring and control cabinet with test stand computer and supply unit for the test specimens
- Two-station machine with manual loading, automatically operated test sequence and manual correction of unbalance.

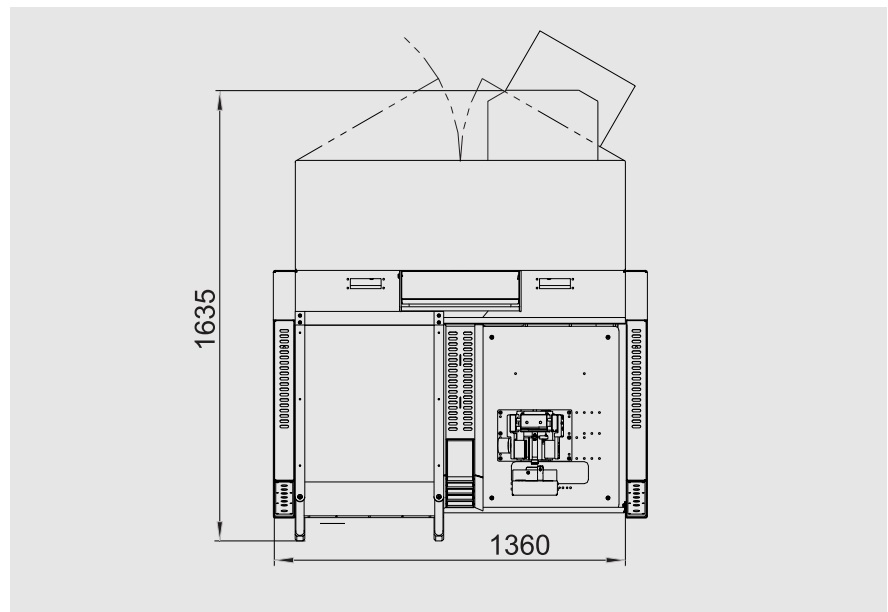

Important data at a glance	Test specimen	Complete automobile fans with incorporated PM motors
	Test method	VAD, signal analysis, unbalance
	Cycle time	Approx. 12 ... 20 sec depending on blower type and on station
	Change-over time	< 5 min

## SCHENCK

### Balancing and Diagnostic Systems

SCHENCK RoTec GmbH  
Landwehrstraße 55  
D-64293 Darmstadt

Tel.: +49 (0) 61 51 - 32 23 11  
Fax: +49 (0) 61 51 - 32 23 15  
eMail: rotec@schenck.net

Make use of our worldwide distribution network.  
For further information please refer to  
<http://www.schenck.net/rotec>